

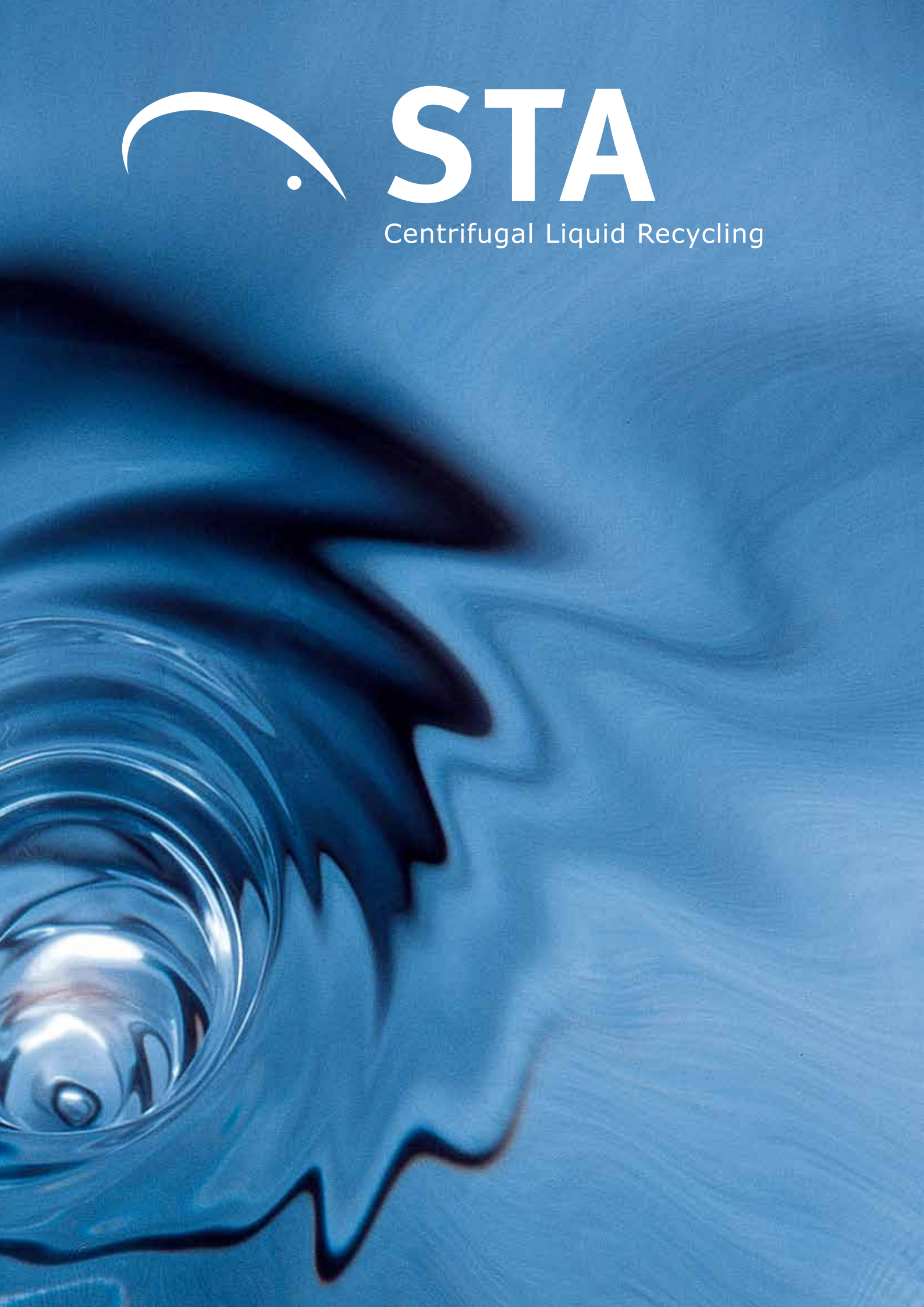

STA

Centrifugal Liquid Recycling



The Discovery of Gravity

Cleaning of industrial fluids with Centrifugal



Technology



STA Centrifugal Separators are using the physical effect of phase separation in centrifugal fields for the cleaning of process fluids.

Even unfilterable media are reliably cleared from particles or secondary liquid phases without use of disposables.

The removed solids are dry and pure.

Centrifugal Separators are relatively compact systems and easy to be integrated; they fit a wide range of applications.



STA

Reliability and Innovation





Since 1992 STA, as a family-run machine building company with more than 30 employees, has always been truly customer-focused.

With application knowledge and thorough system design we are integrating our solutions successfully into our customers' processes.

Relying on modern engineering resources we implement special customer demands quickly and reliably.

Based on the experiences from over 1,500 worldwide installed units, and considering always the latest safety regulations we develop high-performance, long-life and safe machines.

By means of research on our machines' fluid dynamics and extensive field trials we make sure that STA's separators remain the best performing on the market.

We maintain our high quality standards by creating value in our 800 m² production site following certified processes (ISO 9001, WHG 19 L German Water Protection Act).



Application Examples



Glass Working

- Optical glass
- Flat glass, Solar glass, Glass ceramics



Fine Finishing

- Grinding, Lapping, Honing, Deburring
- Machining of tungsten carbide, carbon, ceramics, molybdenum, silicon carbide
- Central and compact systems



Cutting Oil

- from chip drying
- from filter back-flushing

Forming

- Cold forming
- Rolling, Dressing
- Wire drawing



Bypass Fine cleaning

- on central coolant systems
- for grey cast and Al-Si machining



Mass Finishing

- Closed-loop systems
- Wastewater treatment systems



Parts Cleaning

- Central and stand-alone wash media cleaning systems
- High-pressure washing and deburring



Surface Preparation

- Phosphating
- Alkaline Degreasing

PCB Production

- Brushing
- Stripping



Paint Sludge Recovery

- on automated spray-paint systems
- for alkaline and organic stripping

Water Treatment

- Solid charge reduction on evaporation and ultrafiltration systems
- Sludge compression after precipitation

Central Systems



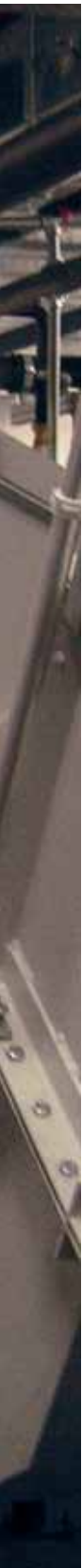

STA Central Filtration Systems are tailored for fluid storing, cleaning and process supply.

Besides our STA-made separators we integrate filters and conveyors, tanks, pumps, coolers, heaters and dosing systems.



You only work with the best machines

Why not when it comes to process fluid cle

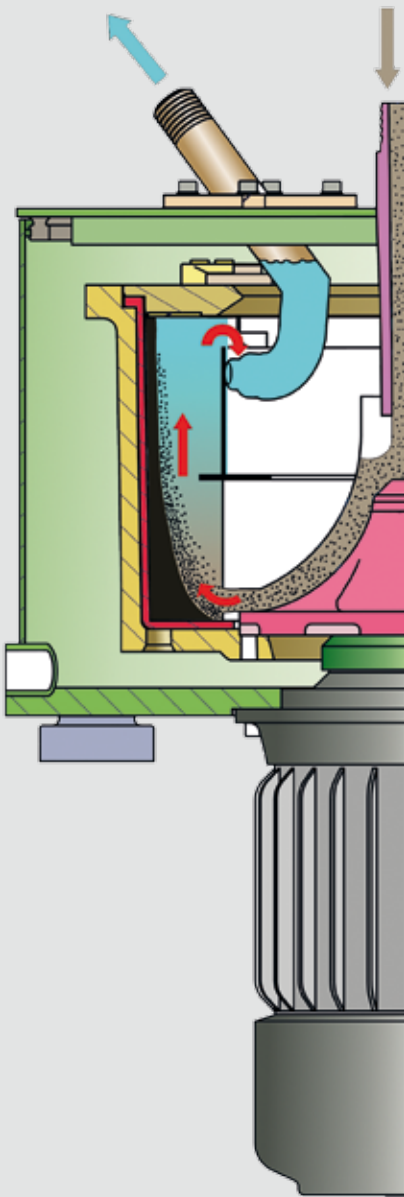

Centrifugal Separator – how it works

- The suspension is fed centrally into the rotor
- Liquid is accelerated and moved outwards
- The solids settle on the inner rotor wall
- The clarified liquid overflows and is discharged via a peeler tube
- For sludge emptying the rotor is stopped



A good spin on separation performance

The fluid-dynamically designed accelerator hub and the big effective flow radius help applying the high rotor accelerations of up to 2.000 g effectively on the liquid and the particles to be separated.

This is why STA Separators reach significant grade efficiencies for particles down to 1 to 3 μm . For high flow rates up to 250 l/min strong drives are selected accordingly.

?

eaning?



Right and Tight

The high acceleration forces also result in an optimum compression of the separated solids. The sludge is dry and can be reasonably disposed or even recycled.



A matter of mud

If you decide to go for a centrifugal separator as your separating system, most parameters relevant to filtration, such as shape and composition of the solids, become forgettable.

Unfilterable additives like greases and polish, or those problematic ingredients in cast alloys namely graphite and silicon just get removed as well.

More examples: chlorinated drawing oils, molybdenum, scales, paint sludge, phosphates, organic slurries,...



It's running already

So quiet you wonder why it's not running. Thanks to its direct drive and the silicon sand filled double casing the separator generates a very low noise level; only 70 dB(A) on the model S-15. Sound-damping housings are rarely necessary.



Not afraid of hot acid

STA Separators are available in different material pairings. For demanding applications in medical or food-related industry, or for use with hot and chemically aggressive media all models can be stainless steel built, in both 304 and 316 Ti alloy, accordingly combined with special sealing materials.

Centrifugal Separators

Semi-automatic



NZ-50

- compact
- direct drive
- pressureless discharge

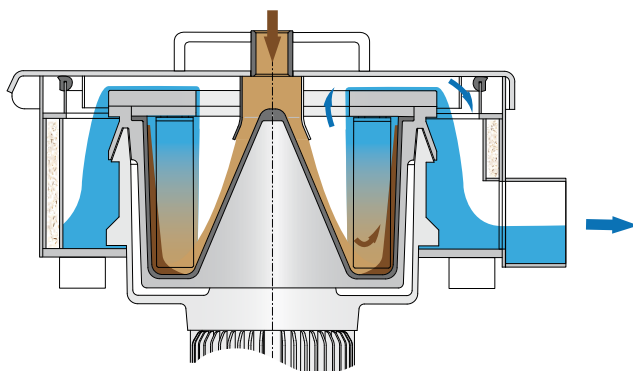

U-15

- fluid-dynamically designed accelerator hub
- direct drive
- peeler tube, backflow head 5 m
- residual liquid drain at standstill

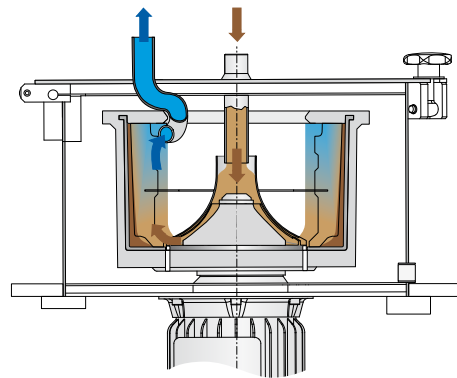

	NZ-50	U-15	S-15
Power	1,5 kW	4 kW	5,5 kW
Rotor volume	4,5 l	15 l	15 l
Sludge capacity	6 kg	12 kg	12 kg
Volume flow	50 l/min 3 m ³ /h	150 l/min 9 m ³ /h	200 l/min 120 m ³ /h
Acceleration	950 g	1960 g	1960 g



S-15

- auto-priming
- low entry level
- direct drive
- silicon sand filled double casing
- peeler tube, backflow head 5 m
- flow rate up to 150 l/min

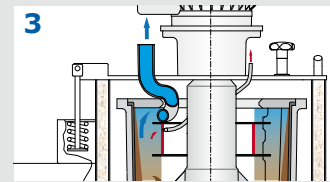
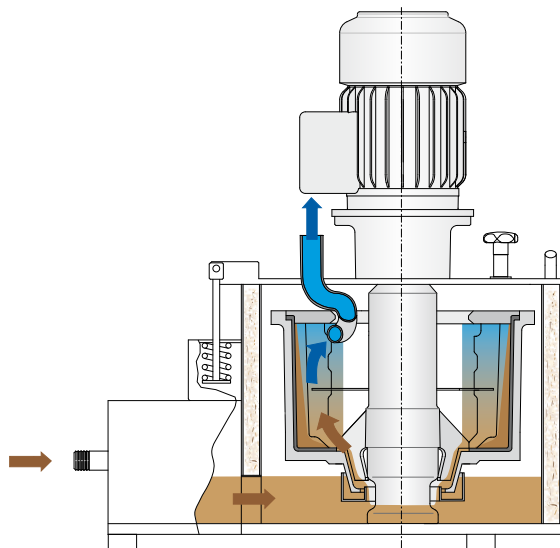

1 One for All - the mobile solution

STA Separators are very compact and space saving, on top of this they can be done mobile, to be even more all-purpose and flexible. Due to their own backflow pressure there is no installation works necessary apart from connecting two tubes.

2 Ready for take-off within 3 minutes

Manual solid discharge is done with almost a flick of the wrist. After only 3 to 5 minutes the separator is ready again for operation.

3 Struck Oil!

As 3-phase separators STA machines are perfectly suited for simultaneous separation of solids and a secondary light liquid phase, such as tramp oil. Applied on coolant or washing emulsions a comprehensive fluid care can be done with a single device. Standard machines already installed can be retrofit on-site with the 3-phase separation kit.

4 Fed-up with tanks and pumps?

The auto-priming S-15 doesn't need tanks nor pumps underneath for residual liquid collection. Entry level only 150 mm! Just place it wherever you want. Or have it run on several volumes: With its auto-valve alternation it will take care of up to 3 or 4 machine tanks in turns.



Centrifugal Separators

Fully automatic



A-12

- very low noise level
- wearless direct drive
- unmatched separation efficiency
- cost-effective: one drive for separation and solid discharge
- very short breaking time



A-25

- noise and vibration damping with double casing, silicon sand filled
- Flow rate up to 250 l/min (15 kW version)
- easy to operate with graphical 6" touch display
- redundant speed and vibration monitoring

	A-12	A-25
Power	7,5 kW	11/15 kW
Rotor volume	15 l	40 l
Sludge Capacity	15 kg/h	40 kg/h
Volume flow	80 l/min 4,8 m ³ /h	150/250 l/min 9/15 m ³ /h
Acceleration	1960 g	1960 g

Separation

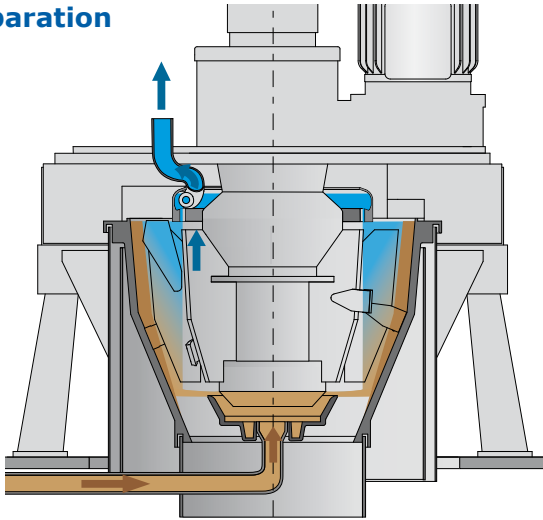

Residual liquid drain and sludge drying

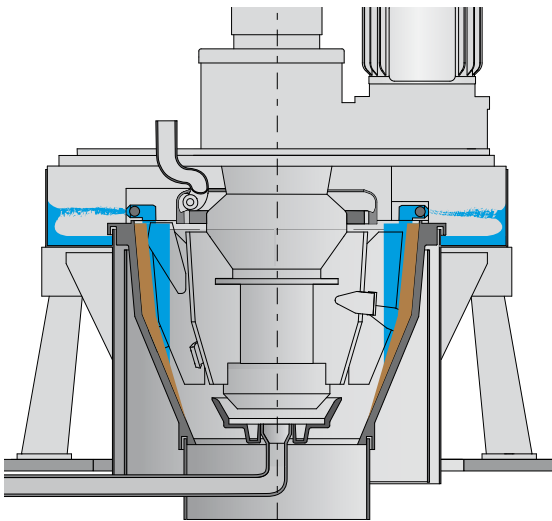

Solids discharge

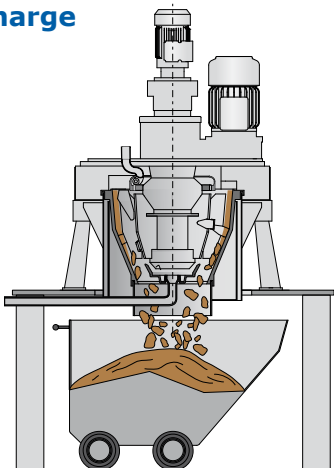

1 The drives: maximum performance and efficiency

The innovative drive concept responds to today's demands for energy efficiency. The inverter controlled 100 Hz drive is more compact than ever, hence very silent and wearless. As an option power modules with low harmonics energy feedback can be used – saving money and improves solids discharge rate by even shorter the breaking times.

2 Improved casing and valve design

Thanks to the rinse liquid drain that has been moved upward and the special centrifugal valve design STA Automates are even less sensitive to sludge deposits, easier to maintain and all-round. Transfer tanks and pumps for rinse liquid are usually not needed.

3 Prepared for a tough job

STA Automatic Separators feature a robust and long-life design, and they are known for reasonable maintenance cost.

For separating hard and abrasive solids, the accelerating and discharging components are furnished with a tungsten carbide antiwear coating. And should it ever become necessary the specially shaped blade tops can be changed even on-site.



Coalescers and Combined Systems

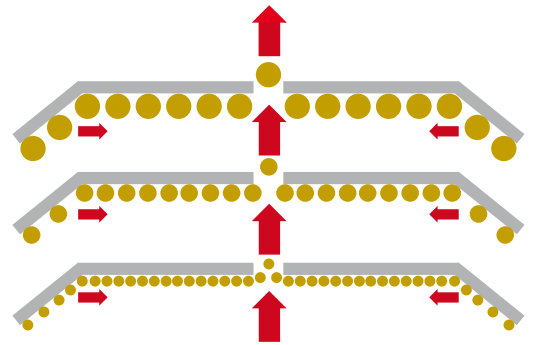

Coalescers for separation of a light liquid secondary phase from a liquid main phase, e.g. tramp oil from wash water

DPS

- static device, completely wear-free
- no consumables
- full stainless steel design
- heat insulation up to 200°C available
- mobile base frames for all-round use
- combine well with Centrifugal Separators as tailored complete bath care systems



Mobile and combined systems



	DPS 100	DPS 350	DPS 700	DPS 1050	DPS 2100	DPS 3000	GLC-50
Volume flow	100 l/h	350 l/h	700 l/h	1.050 l/h	2.100 l/h	3.000 l/h	600 l/h
W [mm]	333	570	570	570	570	582	600
H [mm]	554	544	544	544	570	570	1.219
L [mm]	770	1.020	1.295	1.570	2.409	3.048	1.195

Microfilter Clear Tube

Automatically back-flushing



CTS

- outstanding filtration efficiency: 1-3 μm (NAS 7/8)
- high flow rate at small filter area: 3,5-5 l/min per filter unit
- no need for filter aids
- works with oil (also water-contaminated), water, emulsion
- long filter life
- fully automatic and uninterrupted operation
- separating HSS, tungsten carbide, glass,..
- dry sludge when combined with Centrifugal Separator

	CTS-80	CTS-120	CTS-240	CTS-360	CTS-480
Filter area [m ²]	2,50	4	8	12	16
Volume flow [l/min]	80	120	240	360	480

Service

Focusing on your satisfaction



Laboratory and Rental Service

In our laboratory we analyse your fluid samples, which helps us predict the final separation result in the field. Several test and rental machines are at your disposal for live operation in your production, so you can take your time to discover your benefits.



Installation and Training

Our technicians are skilled experts on whom you can rely on - during commissioning and training as well as for software adaption on site or by remote access.



After Sales Service

STA customers are taken care of throughout their machine's complete life cycle. They benefit from our quick service for spare parts supply and on-site maintenance.



STA

Centrifugal Liquid Recycling



STA Separatoren-Technik & Anlagenbau GmbH

Obere Giesswiesen 32
D-78247 Hilzingen (Germany)
Telefon: +49 (0)77 31 92 43-0
Telefax: +49 (0)77 31 92 43-11
info@sta-separator.de
www.sta-separator.de

